

*In-line centrifugal pumps made of stainless steel AISI 304. Applications include chilled water, air-conditioning systems and heating systems for secondary hot water and general low-pressure applications in industry. Its light construction means installation can be achieved with 1 person where conventionally heavy cast iron & bronze pumps require additional personnel and lifting equipment.*



### SPECIFICATIONS

- Maximum positive suction pressure: 2 bar for all single-phase and for LPS 25 three-phase, 4 bar for LPS 32-40-50 three-phase
- Maximum liquid temperature: 100°C

### MATERIALS

- Pump casing, impeller and casing cover in AISI 304
- Shaft in AISI 303
- Bracket and motor casing in alluminium
- Mechanical seal in carbon/ceramic/NBR

### TECNICAL DATA

- Asincronous 2 poles motor
- Insulation class F
- Protection degree IP55
- 1~230V ± 10% 50Hz - 3~230/400V ± 10% 50Hz
- Permanent split capacitor and automatic thermal overload protection for single-phase version
- Thermal protection to be provided by the user for three-phase version
- Flange: PN10

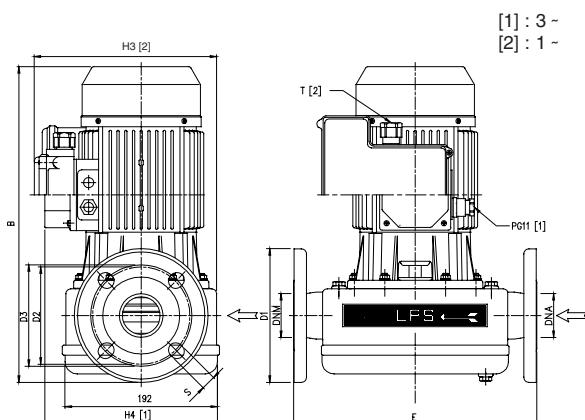

### DIMENSIONAL TABLE

Pump type	Dimension (mm)											Weight (kg)	
	E	B	H3	H4	T	DNM	DNM	D1	D2	D3	S	1~	3~
LPS 25/08	300	320,5	181	171	PG11	25	25	115	85	85	14	12,8	12,8
LPS 25/15	300	320,5	181	171	PG11	25	25	115	85	85	14	12,8	12,8
LPS 25/25	300	320,5	181	171	PG11	25	25	115	85	85	14	12,9	12,9
LPS 32/25	305	340	181	171	PG11	32	32	140	100	100	18	14,6	14,6
LPS 32/40	305	340	181	171	PG11	32	32	140	100	100	18	14,6	14,6
LPS 40/25	305	345	181	171	PG11	40	40	150	105	110	18	13,0	12,5
LPS 40/40	305	345	181	171	PG11	40	40	150	105	110	18	14,0	13,5
LPS 40/75	305	345	181	171	PG11	40	40	150	105	110	18	13,0	12,5
LPS 50/40	310	357,5	181	171	PG11	50	50	165	120	125	18	14,5	14
LPS 50/75	310	357,5	181	171	PG11	50	50	165	120	125	18	15,0	14,5
LPS 50/150	310	389,5	213	194	PG13,5	50	50	165	120	125	18	18,5	18

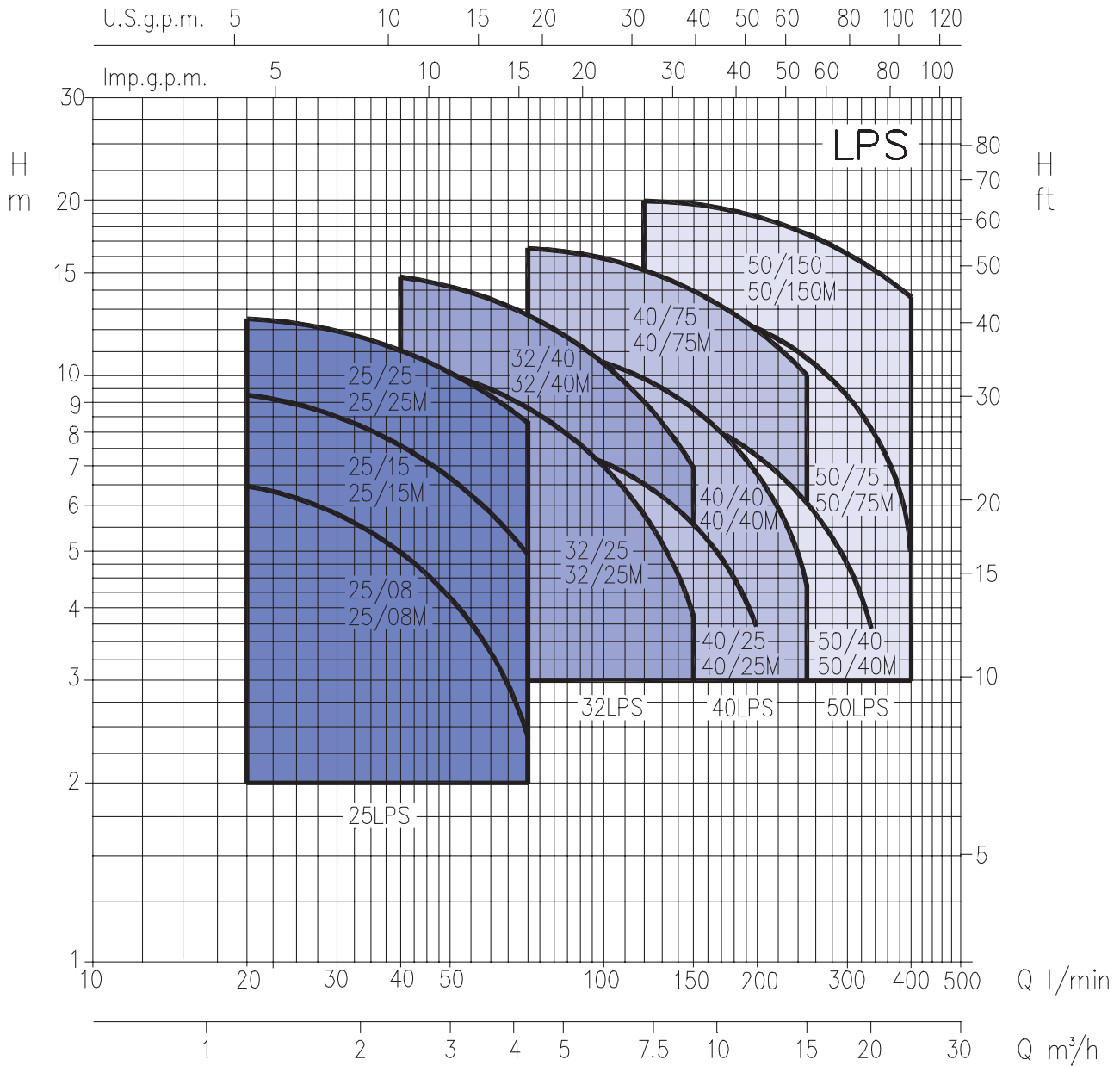
**PERFORMANCE CHART** (according to ISO 9906 Annex A)

**PERFORMANCE TABLE**

Pump type		kW	Capacitor		Absorbed Current (A)			l/min m³/h	Q=Capacity										
Single-phase 230V 50Hz	Three-phase 230/400V 50Hz		µF	V <sub>c</sub>	1~	3~ 230V	400V		20	40	70	100	120	150	200	250	320	400	
								H=Total head											
LPS 25/08 M	LPS 25/08	0,08	12,5	450	1,51	1,7	1,01	6,5	5	2,4	-	-	-	-	-	-	-		
LPS 25/15 M	LPS 25/15	0,15	12,5	450	1,67	1,8	1,03	9,3	7,8	4,9	-	-	-	-	-	-	-		
LPS 25/25 M	LPS 25/25	0,25	12,5	450	2,04	1,9	1,11	12,5	11,1	8,4	-	-	-	-	-	-	-		
LPS 32/25 M	LPS 32/25	0,25	12,5	450	2,0	1,8	1,03	-	10,7	9,1	7,2	5,9	3,9	-	-	-	-		
LPS 32/40 M	LPS 32/40	0,4	12,5	450	2,74	2,2	1,25	-	14,5	12,7	10,6	9,2	7	-	-	-	-		
LPS 40/25 M	LPS 40/25	0,25	12,5	450	1,98	1,9	1,09	-	-	7,8	7,1	6,6	5,6	3,7	-	-	-		
LPS 40/40 M	LPS 40/40	0,4	12,5	450	2,75	2,2	1,25	-	-	11,3	10,4	9,9	8,7	6,9	4,4	-	-		
LPS 40/75 M	LPS 40/75	0,75	25	450	4,86	4,0	2,29	-	-	16,6	16	15,2	14,1	12,3	10,1	-	-		
LPS 50/40 M	LPS 50/40	0,4	12,5	450	2,74	2,2	1,25	-	-	-	-	9,1	8,8	7,4	5,9	3,5	-		
LPS 50/75 M	LPS 50/75	0,75	25	450	4,9	3,9	2,26	-	-	-	-	13,8	13,3	12,3	10,7	8,2	5		
LPS 50/150 M	LPS 50/150	1,5	35	450	8,07	5,7	3,31	-	-	-	-	19,8	19,3	18,7	17,8	16	13,7		

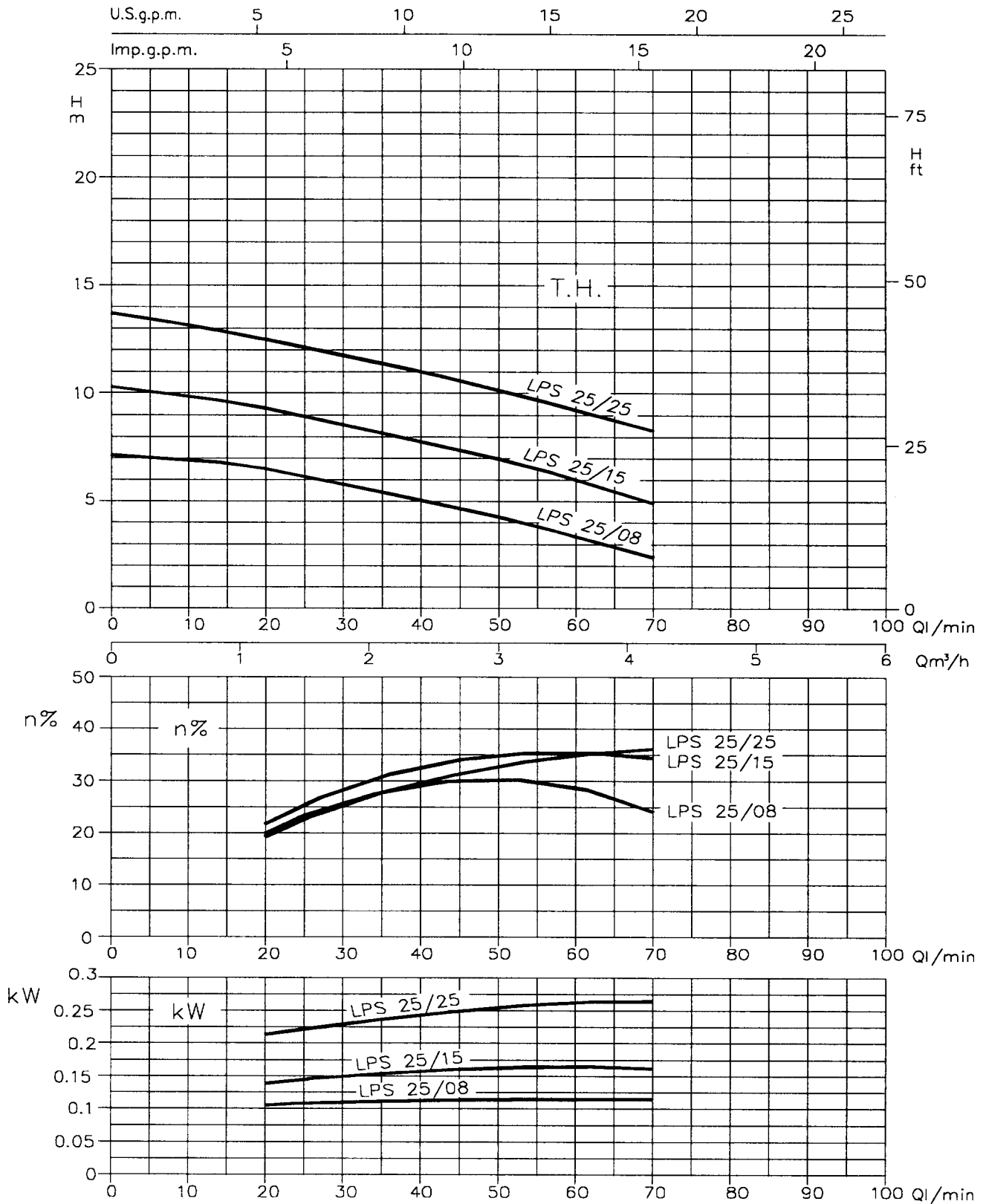
**PERFORMANCE CURVES LPS 25 series** (according to ISO 9906 Annex A)

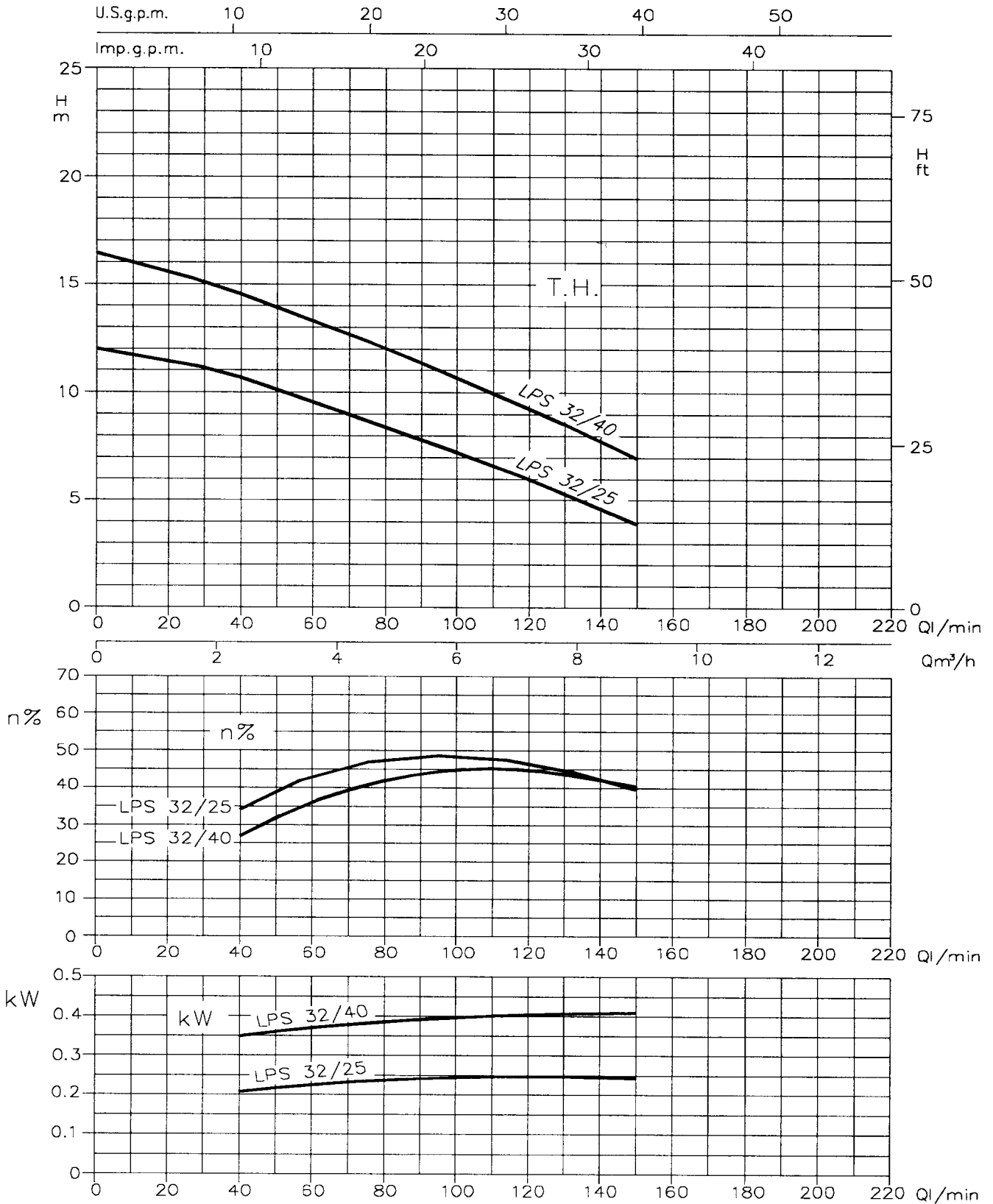

**PERFORMANCE CURVES LPS 32 series** (according to ISO 9906 Annex A)



**PERFORMANCE CURVES LPS 40 series** (according to ISO 9906 Annex A)

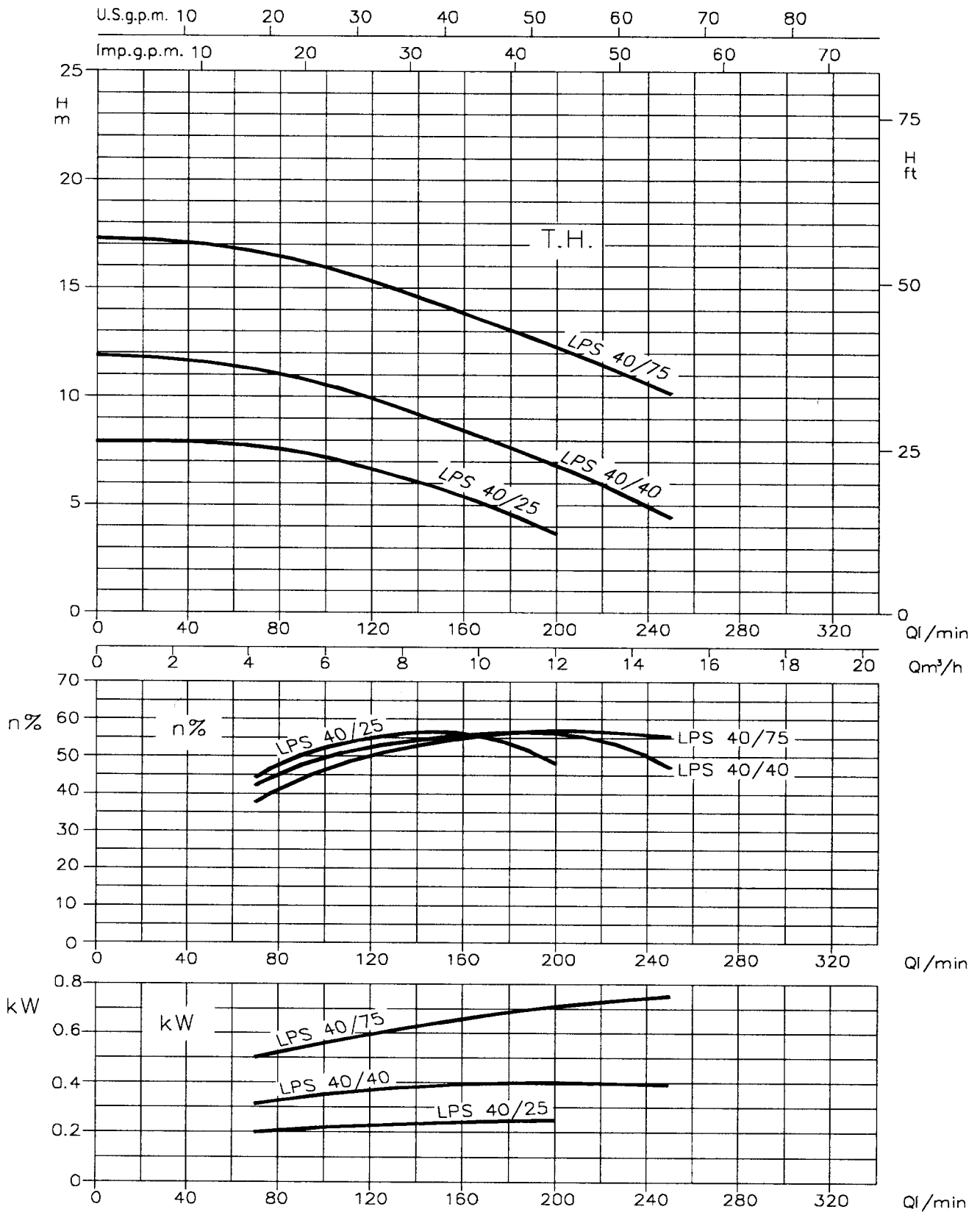

**PERFORMANCE CURVES LPS 50 series** (according to ISO 9906 Annex A)

