



EBARA

# DW - DW VOX

SUBMERSIBLE SEWAGE PUMPS



## DW - DW VOX

EBARA presents the **DW - DW VOX** Submersible Pump. The **ONLY** submersible pump for light screened Sewage and dirty water. The pump is manufactured entirely from a single sheet of 304 stainless steel using the EBARA pressing method. Comprising of a single channel impeller or "Vortex" style and incorporating a double mechanical seal. The volute of the **DW - DW VOX** is made as an integral part of the pump casing using the EBARA patented pressing technology.



## APPLICATIONS

- Removal of treated liquid waste.
- Draining of building sites.
- Draining of sump pits.
- Emergency drainage pumps for flood protection.
- Tank emptying.
- General dirty water duties.

## TECHNICAL CHARACTERISTICS

Completely pressed from 304 stainless steel.

Pump body and spiral volute produced using EBARA patented technology.

**DW** = Single Channel Impeller.

**DW VOX** = Open fronted impeller - "Vortex" style in recessed position.

- Lifting handle provided as standard.
- Shaft extension made in 304 stainless steel.
- Double mechanical seal with oil chamber for lubrication.
- Mechanical seal components - graphite/ceramic and silicon carbide/silicon carbide.

## SELECTION CHART

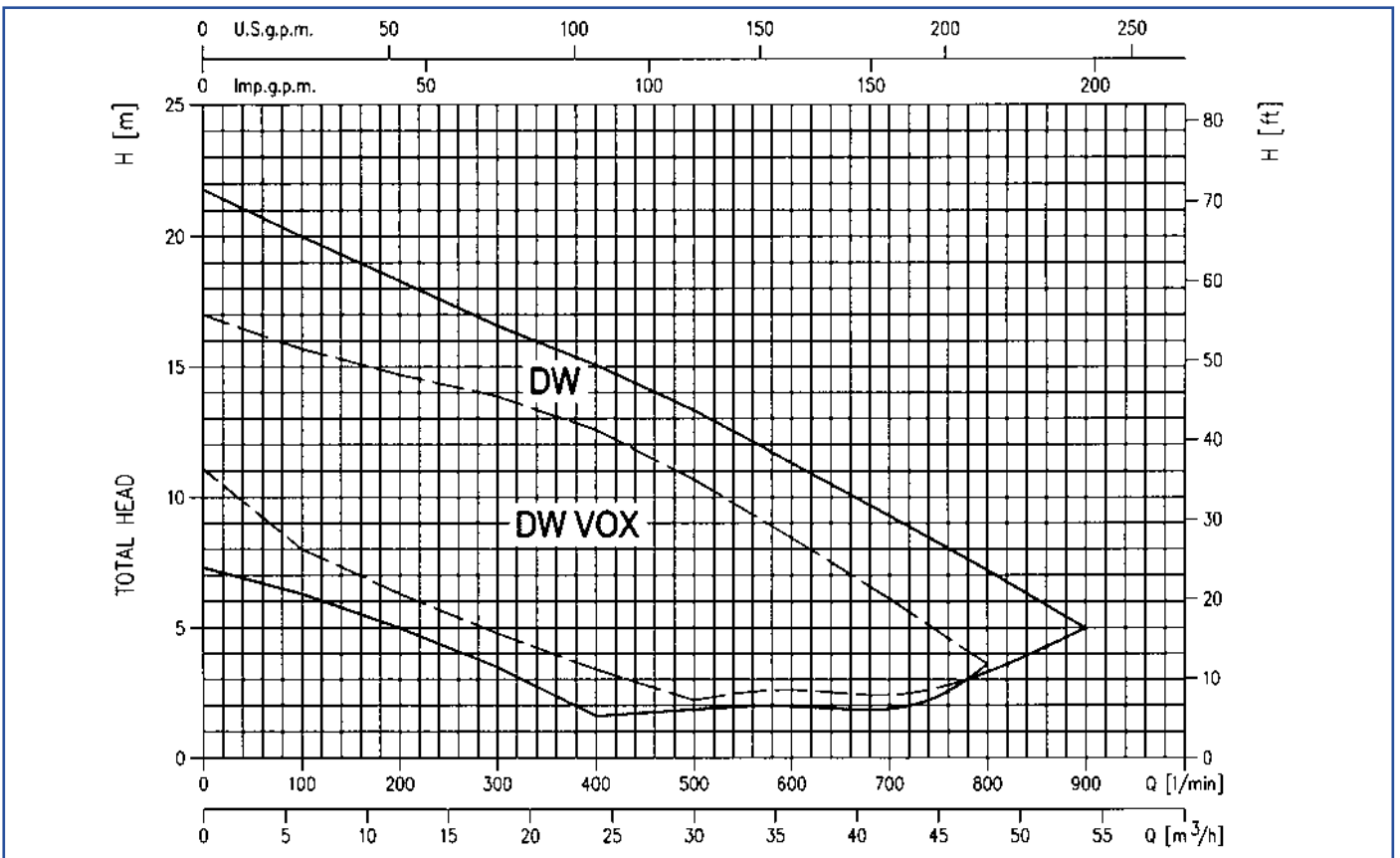

Pump type	kW	HP	Q = Capacity										
			l/min m³/h	0	100	200	300	400	500	600	700	800	900
				0	6	12	18	24	30	36	42	48	54
			H = Total manometric head in meters										
DW 75	0.55	0.75	11.1	8	6.3	4.8	3.4	2.2	—	—	—	—	—
DW 100	0.75	1	13.3	10.6	8.7	7.1	5.5	4	2.6	—	—	—	—
DW 150	1.1	1.5	15	13.1	11.3	9.5	7.7	5.9	4.2	2.4	—	—	—
DW 200	1.5	2	18.2	16.6	15	13.3	11.4	9.5	7.5	5.4	3.3	—	—
DW 300	2.2	3	21.8	20	18.3	16.6	15.1	13.3	11.3	9.3	7.2	5	—
DW VOX 75	0.55	0.75	7.3	6.3	5	3.5	1.6	—	—	—	—	—	—
DW VOX 100	0.75	1	9	7.9	6.7	5.3	3.7	1.9	—	—	—	—	—
DW VOX 150	1.1	1.5	11.4	10.2	9	7.6	6.1	4.1	2.1	—	—	—	—
DW VOX 200	1.5	2	13.8	12.5	11.2	9.8	8.3	6.4	4.2	1.6	—	—	—
DW VOX 300	2.2	3	17	15.7	14.7	13.9	12.6	10.7	8.4	6.1	3.6	—	—

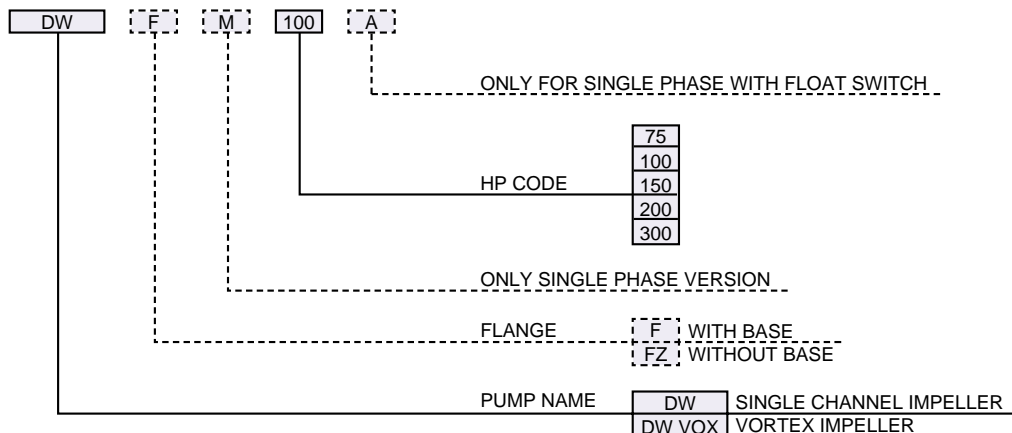

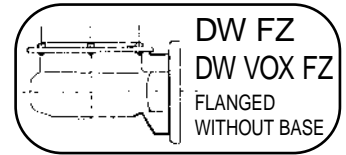
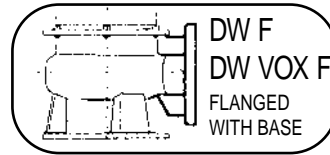
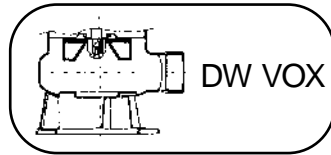
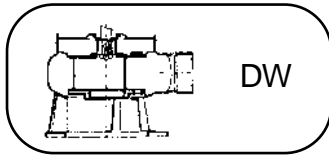

## SPECIFICATIONS

PUMP		
Liquid Handled	Type of liquid	Dirty water, sewage water
	Max temperature [°C]	40
	Max solids size [mm]	50 spherical
Maximum immersion	[m]	10
Construction	Impeller	Single channel (DW) Vortex (DW VOX)
	Shaft seal type	Double mechanical seal
	Bearing	Sealed ball bearing
Pipe connection	Suction-Flange [mm]	50 Open
	Discharge-Flange	G 2
Material	Casing	AISI 304
	Impeller	AISI 304
	Casing cover	AISI 304
	Shaft seal	Pump side: SiC/SiC/NBR Motor side: Carbon/Ceramic/NBR
	Seal cover	AISI 304
	Shaft	AISI 303 (Part in contact with liquid)
	Lubricating liquid	White mineral oil: Esso Marcol 172 (385 cc)
Applicable standard of test		ISO 9906 grade 2

MOTOR			
Type	Submersible dry type		
	Single Phase	Three Phase	
No. of Poles	2		
Rotation speed [min <sup>-1</sup> ]	≈2800		
Insulation Class	F		
Protection degree	IP 68		
Power rating	[kW]	0.55 ÷ 1.1	0.55 ÷ 2.2
	[HP]	0.75 ÷ 1.5	0.75 ÷ 3
Frequency [Hz]	50		
Voltage [V]	230 ± 10%	400 ± 10%	
Capacitor	Built in	-	
Over load protection	Built in	Provided by the user	
Float switch	Optional	-	
Float switch cable	material	H07RN-F	-
	size	3G1	-
Casing material	AISI 304		
Base material/motor support	AISI 304		
Power cable	length [m]	10	
	material	H07RN-F	
	size	3G1 (up to 0.55 kW) 3G1.5 (from 0.75 to 1.1 kW)	4G1.5 + 2x0.5
Dimensions of cable entry	Cable Gland		

## TECHNICAL DATA

### DW

Type pumps		Power		Capacitor		Input power		Full load current		Locked rotor current	
Single Phase 230 V 50 Hz	Three Phase 400 V 50 Hz	[kW]	[HP]	Single Phase		[kW]		[A]		[A]	
				[ $\mu$ F]	V <sub>C</sub> [V]	Single Phase	Three Phase	Single Phase	Three Phase	Single Phase	Three Phase
75 M	75	0.55	0.75	20	450	0.9	0.85	3.9	1.5	17	8.5
100 M	100	0.75	1	25	450	1.28	1.19	5.9	2.1	26	14.2
150 M	150	1.1	1.5	31.5	450	1.57	1.55	7.3	2.8	35	24.2
-	200	1.5	2	-	-	-	2.08	-	3.6	-	30
-	300	2.2	3	-	-	-	2.9	-	5.0	-	45

### DW VOX

Type pumps		Power		Capacitor		Input power		Full load current		Locked rotor current	
Single Phase 230 V 50 Hz	Three Phase 400 V 50 Hz	[kW]	[HP]	Single Phase		[kW]		[A]		[A]	
				[ $\mu$ F]	V <sub>C</sub> [V]	Single Phase	Three Phase	Single Phase	Three Phase	Single Phase	Three Phase
75 M	75	0.55	0.75	20	450	0.88	0.80	3.9	1.4	17	8.5
100 M	100	0.75	1	25	450	1.25	1.18	5.8	2.1	26	14.2
150 M	150	1.1	1.5	31.5	450	1.58	1.57	7.3	2.8	35	24.2
-	200	1.5	2	-	-	-	1.92	-	3.3	-	30
-	300	2.2	3	-	-	-	2.4	-	4.4	-	45

### DW - DW VOX

Type pumps		Ball Bearing	
Single Phase 230 V 50 Hz	Three Phase 400 V 50 Hz	Pump side	Cover side
75 M	75	6303 ZZ	6203 ZZ
100 M	100	6303 ZZ	6203 ZZ
150 M	150	6303 ZZ	6203 ZZ
-	200	6303 ZZ	6203 ZZ
-	300	6303 ZZ	6203 ZZ

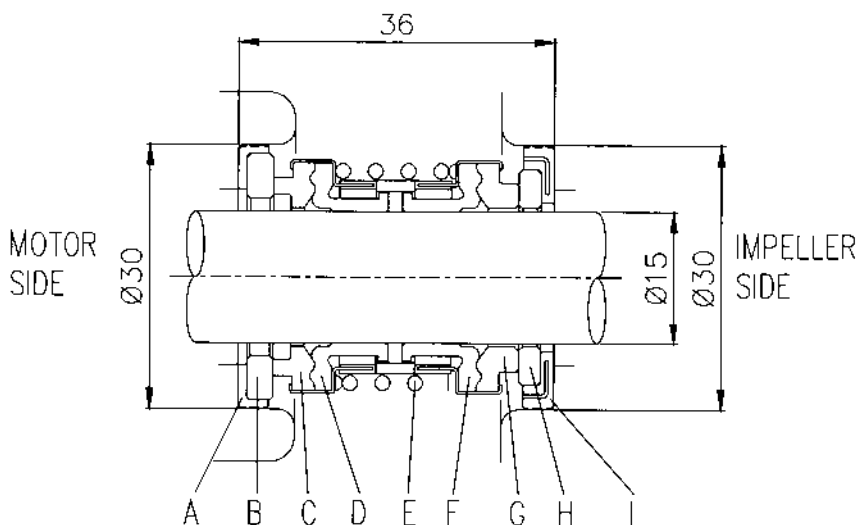

Ref	Part Name	Material
A	Rubber seat	NBR
B	Stationary ring	Ceramic
C	Rotary ring	Carbon
D	Rotary seal	NBR
E	Coil spring	AISI 304
F	Rotary seal	NBR
G	Rotary ring	Silicon Carbide
H	Stationary ring	Silicon Carbide
I	Rubber seat	NBR

# DW PERFORMANCE CHART

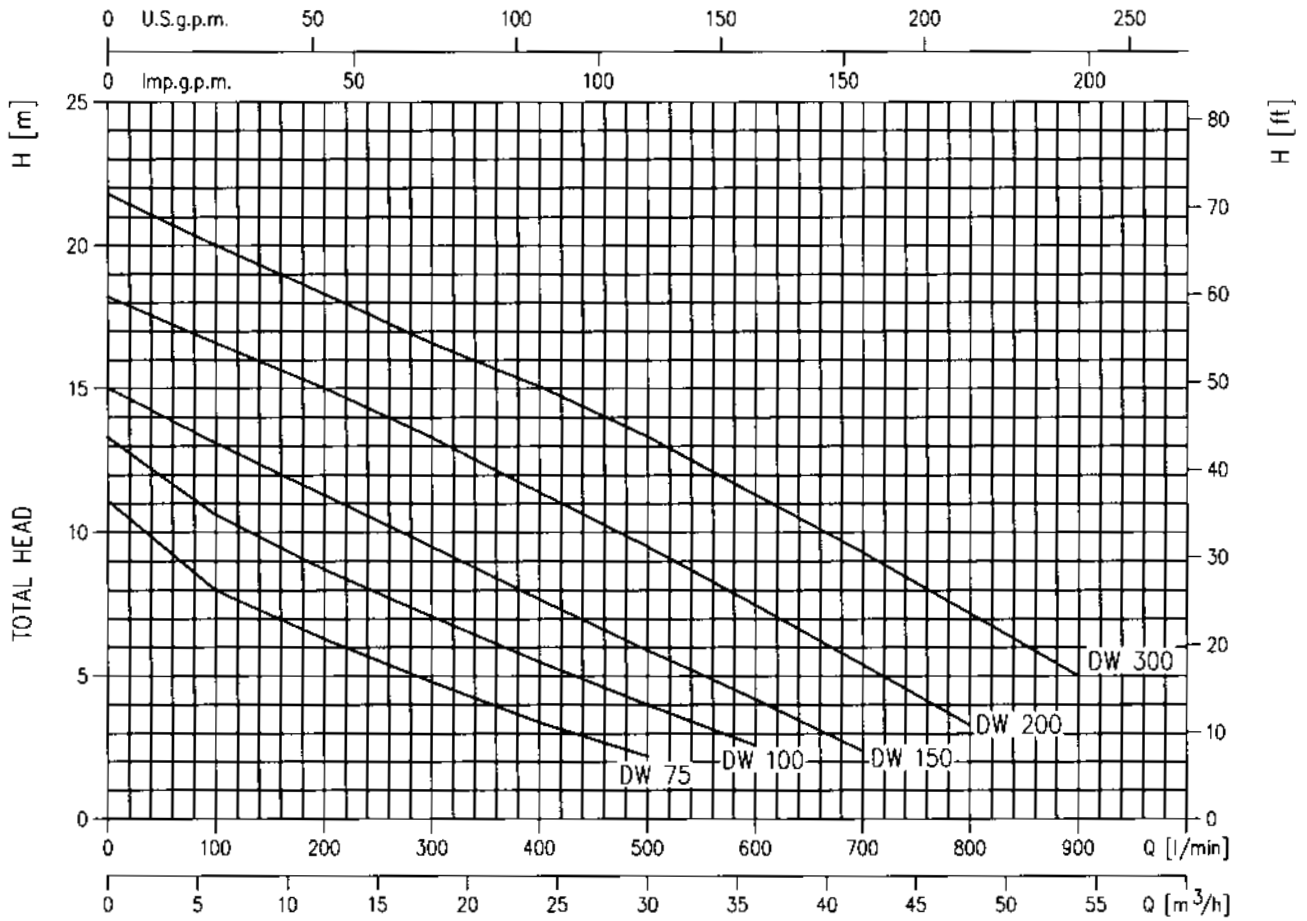
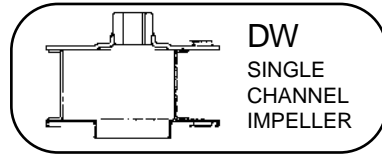

R.P.M.:  $\approx 2800 \text{ min}^{-1}$   
 Test fluid: clean water at  $20^\circ\text{C}$   
 Applicable standard of test: ISO 9906 grade 2

# DW VOX PERFORMANCE CHART

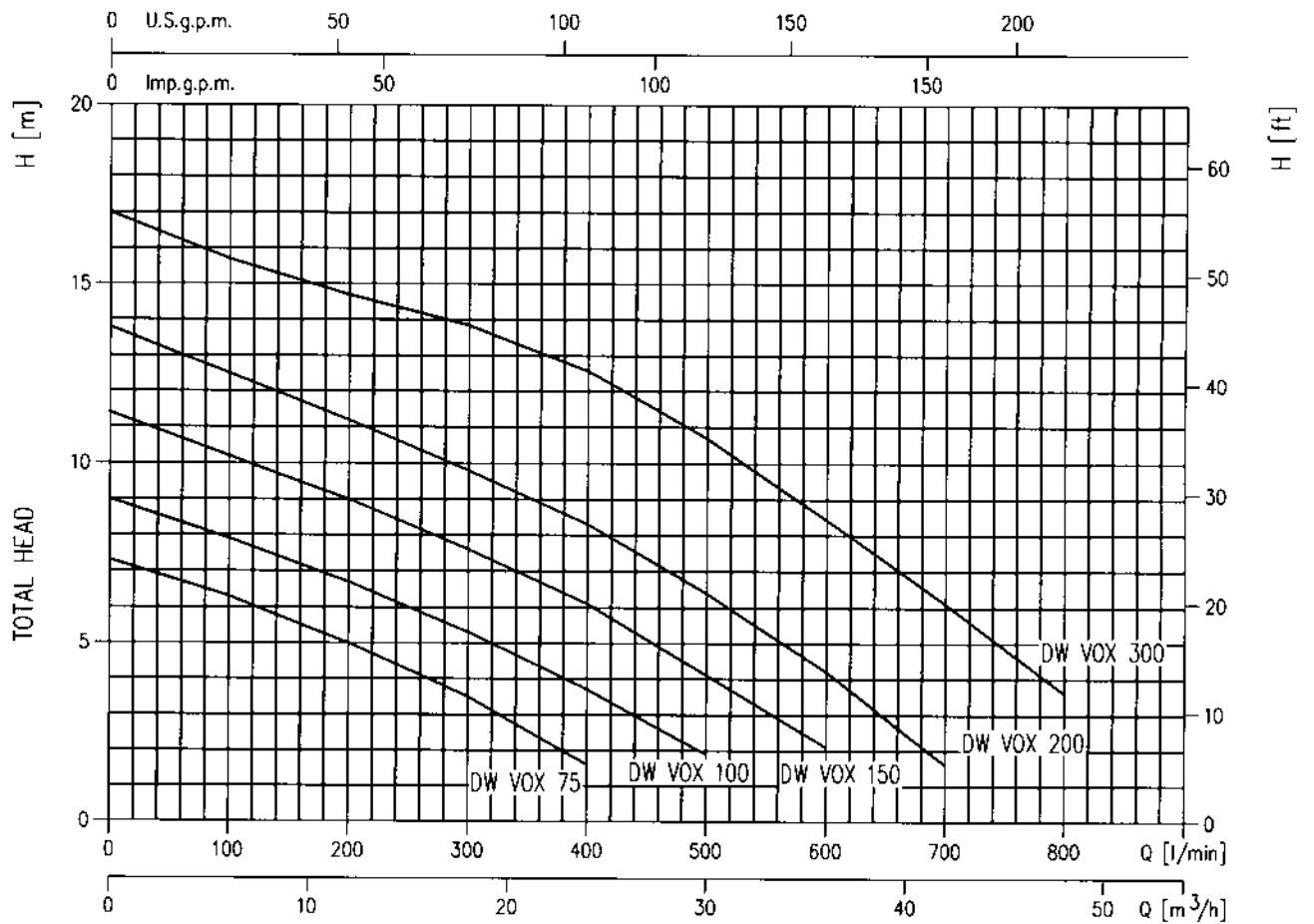
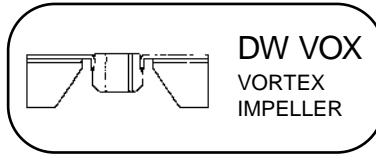

R.P.M.:  $\approx 2800 \text{ min}^{-1}$   
 Test fluid: clean water at  $20^\circ\text{C}$   
 Applicable standard of test: ISO 9906 grade 2

## SECTIONAL VIEW

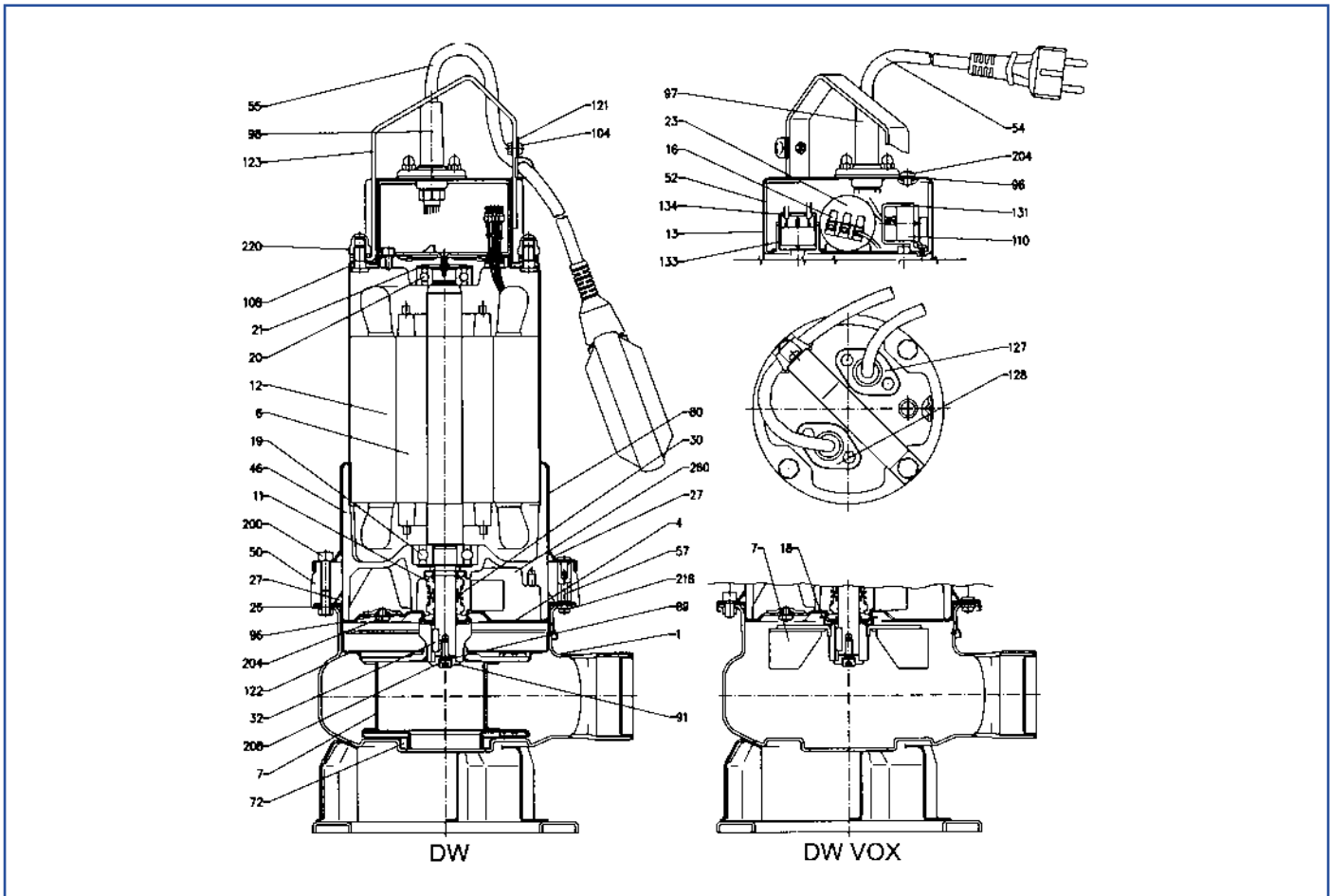

N°	Part name	Material	Q.ty
1	Casing	AISI 304	1
4	Casing cover	AISI 304	1
6	Shaft with rotor	AISI 304	1
7	Impeller	AISI 304	1
11	Mechanical seal	SiC/SiC/NBR	1
11	Mechanical seal	Carbon/Ceramic/NBR	1
12	Motor frame with stator	-	1
13	Motor cover	AISI 304	1
16	Terminal	-	1
18	Mechanical seal protection [4]	AISI 304	1
19	Lower side ball bearing	-	1
20	Upper side ball bearing	-	1
21	Adjusting ring	Steel C70	1
23	Capacitor [1]	-	1
26	O ring	NBR	1
27	O ring	NBR	1
27	O ring [6]	NBR	1
30	Mechanical seal spacer	Brass	1
32	Key	AISI 304	1
46	Bearing housing	G20	1
50	Spacer [6]	G20	1
52	Terminal insulating box	Nylon	1
54	Power cable	-	1
55	Float switch [2]	-	1

N°	Part name	Material	Q.ty
57	Spacer [6]	AISI 304	4
72	Casing ring [5]	NBR	1
89	Washer	AISI 304	1
91	Washer	AISI 304	1
96	O ring	NBR	3
97	Power cable entry	NBR	1
98	Floating sw cable entry [2]	NBR	1
104	Cable entry for support [2]	NBR	1
108	Cover packing	NBR	1
110	Protector [1]	-	2
121	Support for float switch [2]	AISI 304	1
122	Impeller protection ring [7]	AISI 304	1
123	Handle	AISI 304	1
127	Power cable connector	AISI 304	1
128	Floating sw. cable connector [2]	AISI 304	1
131	Support for protector [3]	Nylon	1
133	Support for probe [3]	Aluminium	1
134	Cover for support probe [3]	Nylon	1
200	Screw	Stainless steel A2 UNI 7323	6
204	Screw	Stainless steel A2 UNI 7323	3
208	Screw	Stainless steel A2 UNI 7323	1
218	Nut	Stainless steel A2 UNI 7323	4
220	Nut	Stainless steel A2 UNI 7323	4
260	Lubricating liquid	White mineral oil	385 cc

[1] Only for single phase

[2] Only for single phase with float switch

[3] Only for single phase DW 150

[4] Except for DW-DW VOX 300

[5] Only for DW

[6] Only for DW-DW VOX 300

[7] Except for DW VOX 150,200 and 300

# PART LIST

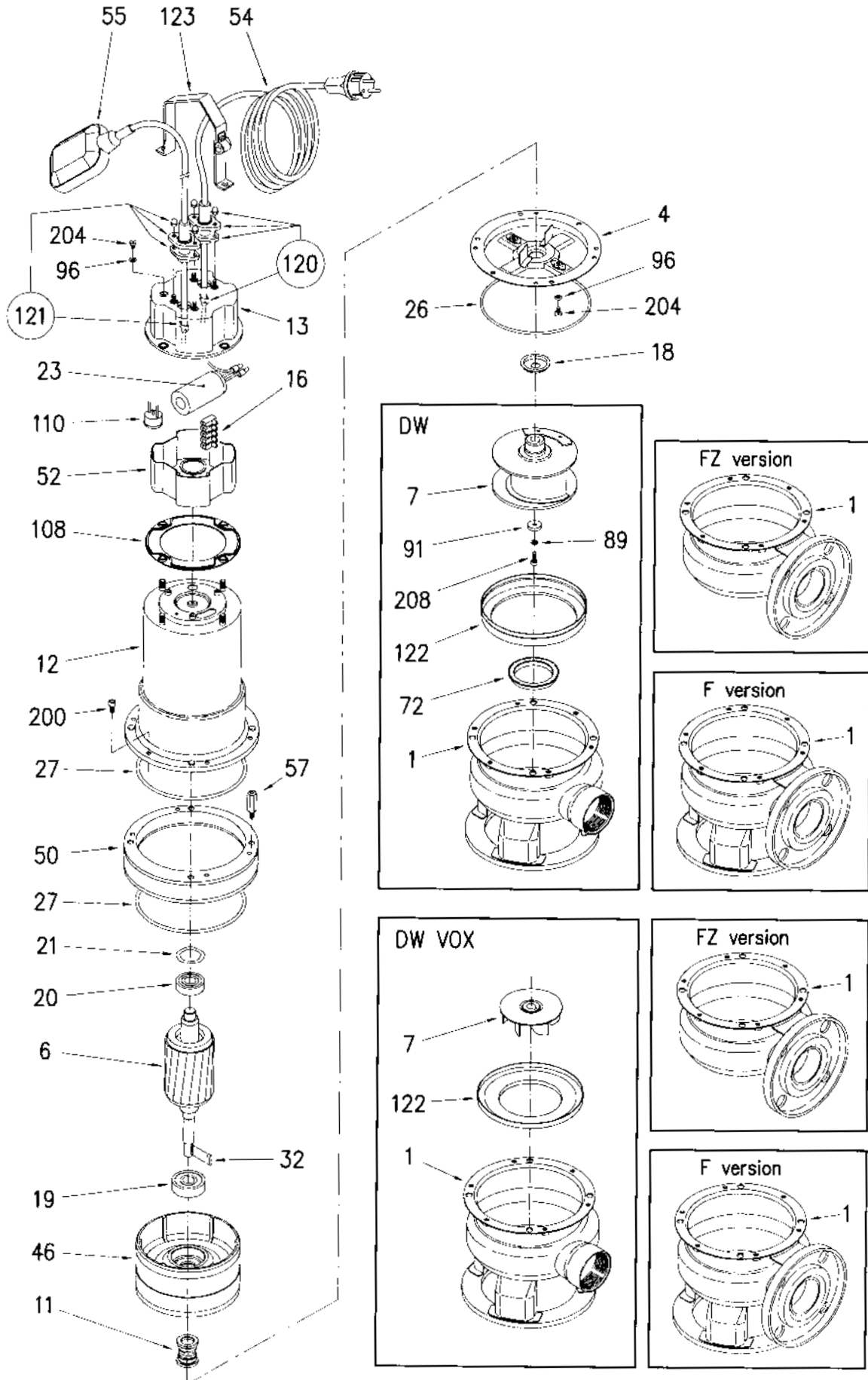

## DW - DWF - DWFZ DIMENSIONS

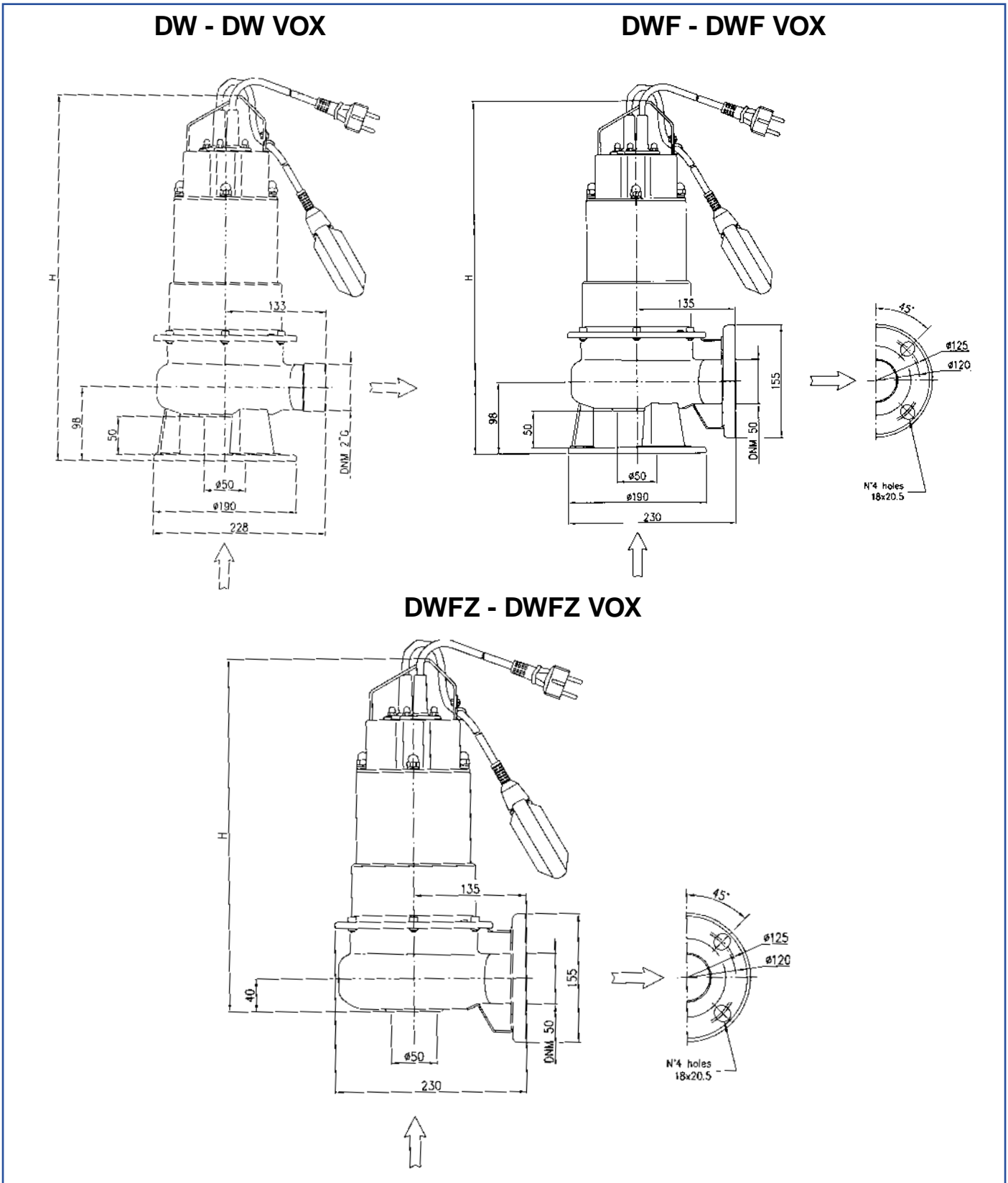

Pump type	H [mm]
DW 75 (VOX)	485
DW 100 (VOX)	515
DW 150 (VOX)	515
DW 200 (VOX)	515
DW 300 (VOX)	545

Pump type	H [mm]
DWF 75 (VOX)	485
DWF 100 (VOX)	515
DWF 150 (VOX)	515
DWF 200 (VOX)	515
DWF 300 (VOX)	545

Pump type	H [mm]
DWFZ 75 (VOX)	427
DWFZ 100 (VOX)	457
DWFZ 150 (VOX)	457
DWFZ 200 (VOX)	457
DWFZ 300 (VOX)	487

## INSTALLATION

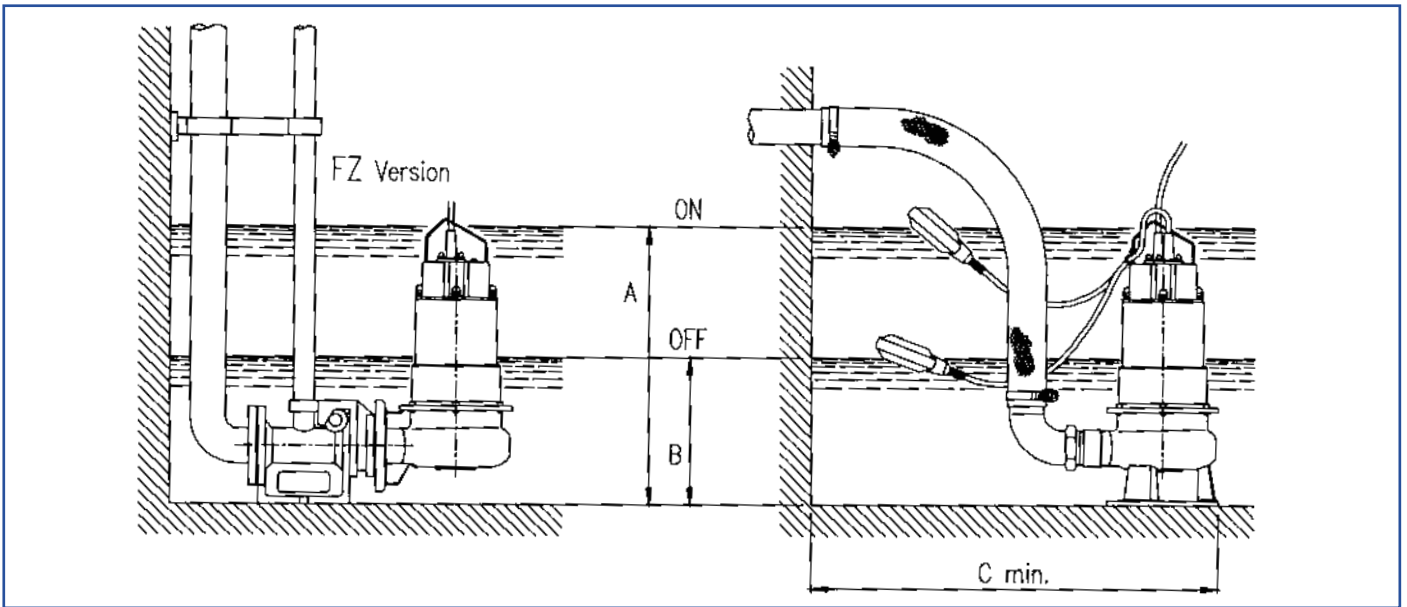

Dimensions [mm]	
A	600
B	250
C	500

## PACKING AND WEIGHT

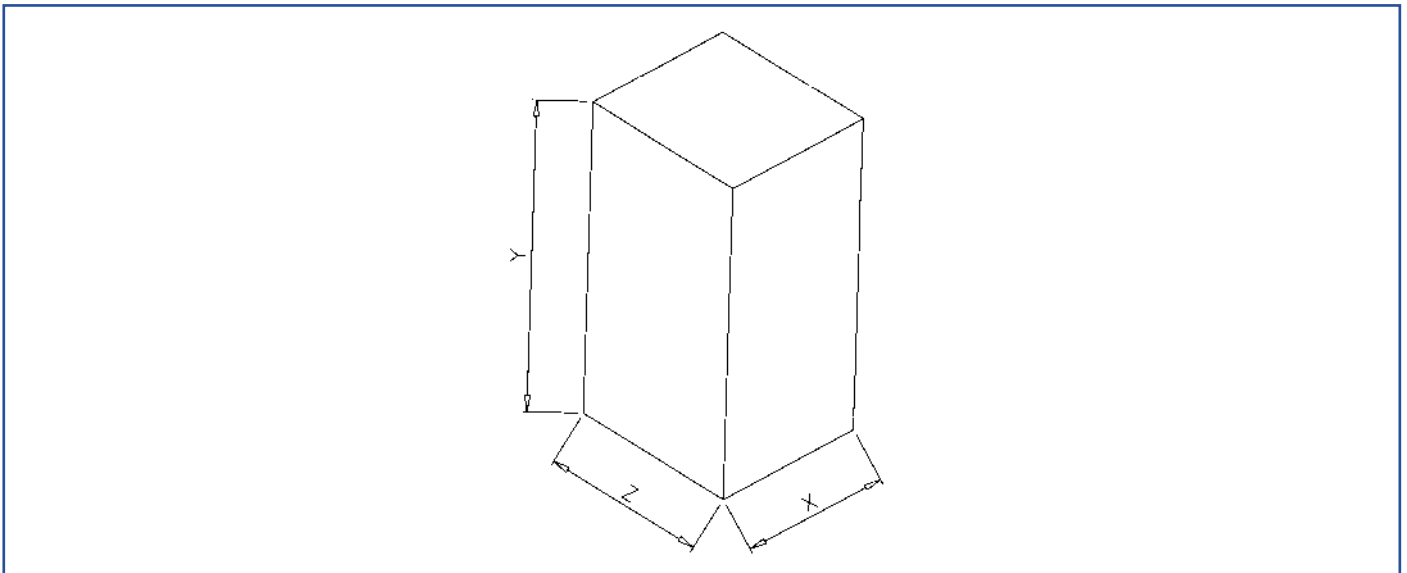

Type pumps		Packing [mm]			Pump weight [Kg]	
Single Phase	Three Phase	Z	X	Y	Single Phase	Three Phase
DW 75 M	DW 75	290	260	550	16	16
DW 100 M	DW 100	290	260	550	18	18
DW 150 M	DW 150	290	260	550	20	20
–	DW 200	290	260	550	–	20
–	DW 300	290	260	550	–	26
DW VOX 75 M	DW VOX 75	290	260	550	16	16
DW VOX 100 M	DW VOX 100	290	260	550	18	18
DW VOX 150 M	DW VOX 150	290	260	550	20	20
–	DW VOX 200	290	260	550	–	20
–	DW VOX 300	290	260	550	–	26